

Models 358 & 359

Thick Shake Freezers

Operating Instructions

056788-M



TAYLOR[®]

8/2/10 (Original Publication)
(Updated 3/18/11)

Complete this page for quick reference when service is required:

Taylor Distributor: _____

Address: _____

Phone: _____

Service: _____

Parts: _____

Date of Installation: _____

Information found on the data label:

Model Number: _____

Serial Number: _____

Electrical Specs: Voltage _____ Cycle _____

Phase _____

Maximum Fuse Size: _____ A

Minimum Wire Ampacity: _____ A

© August, 2010 Taylor
All rights reserved.
056788-M



*The word Taylor and the Crown design
are registered trademarks in the United States
of America and certain other countries.*

Taylor Company
750 N. Blackhawk Blvd.
Rockton, IL 61072

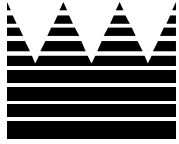

Table of Contents

Section 1	To the Installer	1
	Installer Safety	1
	Site Preparation	1
	Air Cooled Units	2
	Electrical Connections	2
	Beater Rotation	2
	Refrigerant	3
Section 2	To the Operator	4
Section 3	Safety	5
Section 4	Operator Parts Identification	7
	Model 358	7
	Model 359	8
	Beater and Door Assembly	9
	Accessories	10
Section 5	Important: To the Operator	11
	Power Switch	11
	Indicator Light - "Mix Out"	12
	Reset Button	12
	Air Tube	12
Section 6	Operating Procedures	13
	Assembly	13
	Sanitizing	16
	Priming	17
	Closing Procedure	18
	Draining Product From the Freezing Cylinder	18
	Rinsing	18

Cleaning	19
Disassembly	19
Brush Cleaning	19
Section 7 Important: Operator Checklist	21
During Cleaning and Sanitizing	21
Troubleshooting Bacterial Count	21
Regular Maintenance Checks	21
Winter Storage	22
Section 8 Troubleshooting Guide	23
Section 9 Parts Replacement Schedule	26
Section 10 Parts List	27
Wiring Diagrams	34

Note: Continuing research results in steady improvements; therefore, information in this manual is subject to change without notice.

© August, 2010 Taylor (Original Publication)
(Updated March, 2011)
All rights reserved.
056788-M



*The word Taylor and the Crown design
are registered trademarks in the United States
of America and certain other countries.*

Taylor Company
750 N. Blackhawk Blvd.
Rockton, IL 61072

Section 1

To the Installer

The following are general installation instructions. For complete installation details, please see the checkout card.

Installer Safety



In all areas of the world, equipment should be installed in accordance with existing local codes. Please contact your local authorities if you have any questions.

Care should be taken to ensure that all basic safety practices are followed during the installation and servicing activities related to the installation and service of Taylor equipment.

- Only authorized Taylor service personnel should perform installation and repairs on the equipment.
- Authorized service personnel should consult OSHA Standard 29CFR1910.147 or the applicable code of the local area for the industry standards on lockout/tagout procedures before beginning any installation or repairs.
- Authorized service personnel must ensure that the proper PPE is available and worn when required during installation and service.
- Authorized service personnel must remove all metal jewelry, rings, and watches before working on electrical equipment.



The main power supply(s) to the freezer must be disconnected prior to performing any repairs. Failure to follow this instruction may result in personal injury or death from electrical shock or hazardous moving parts as well as poor performance or damage to the equipment.

Note: All repairs must be performed by an authorized Taylor Service Technician.



This unit has many sharp edges that can cause severe injuries.

Site Preparation

Review the area where the unit will be installed before uncrating the unit. Make sure all possible hazards to the user or equipment have been addressed.

For Indoor Use Only: This unit is designed to operate indoors, under normal ambient temperatures of 70°-75°F (21°-24°C). The freezer has successfully performed in high ambient temperatures of 104° (40°C) at reduced capacities.



This unit must **NOT** be installed in an area where a water jet or hose can be used. **NEVER** use a water jet or hose to rinse or clean the unit. Failure to follow this instruction may result in electrocution.



This unit must be installed on a level surface to avoid the hazard of tipping. Extreme care should be taken when moving this equipment for any reason. Two or more persons are required to safely move this unit. Failure to comply may result in personal injury or equipment damage.

Uncrate the unit and inspect it for damage. Report any damage to your Taylor Distributor.

This piece of equipment is made in the USA and has USA sizes of hardware. All metric conversions are approximate and vary in size.

Air Cooled Units

DO NOT obstruct air intake and discharge openings:

Air cooled units require a minimum of 3" (76 mm) of clearance around all sides of the freezers and 3-1/2" (89 mm) on the bottom.

Model 359 only: Installation of air deflector is required.

Failure to allow adequate clearance can reduce the refrigeration capacity of the freezers and possibly cause permanent damage to the compressors.

Electrical Connections

In the United States, this equipment is intended to be installed in accordance with the National Electrical Code (NEC), ANSI/NFPA 70-1987. The purpose of the NEC code is the practical safeguarding of persons and property from hazards arising from the use of electricity. This code contains provisions considered necessary for safety. In all other areas of the world, equipment should be installed in accordance with the existing local codes. Please contact your local authorities.



Each freezer requires one power supply for each data label on the freezer. Check the data label(s) on the freezer for branch circuit overcurrent protection or fuse, circuit ampacity and other electrical specifications. Refer to the wiring diagram provided inside the control box for proper power connections.



CAUTION: THIS EQUIPMENT MUST BE PROPERLY GROUNDED! FAILURE TO DO SO CAN RESULT IN SEVERE PERSONAL INJURY FROM ELECTRICAL SHOCK!



This unit is provided with an equipotential grounding lug that is to be properly attached to the rear of the frame by the authorized installer. The installation location is marked by the equipotential bonding symbol (5021 of IEC 60417-1) on both the removable panel and the equipment's frame.



- Stationary appliances which are not equipped with a power cord and a plug or another device to disconnect the appliance from the power source must have an all-pole disconnecting device with a contact gap of at least 3 mm installed in the external installation.
- Appliances that are permanently connected to fixed wiring and for which leakage currents may exceed 10 mA, particularly when disconnected, not used for long periods, or during initial installation, shall have protective devices such as a GFI to protect against the leakage of current, installed by authorized personnel to the local codes.
- Supply cords used with this unit shall be oil-resistant, sheathed flexible cable, not lighter than ordinary polychloroprene or other equivalent synthetic elastomer-sheathed cord (Code designation 60245 IEC 57) installed with the proper cord anchorage to relieve conductors from strain, including twisting, at the terminals and protect the insulation of the conductors from abrasion.

Beater Rotation



Beater rotation must be clockwise as viewed looking into the freezing cylinder.

Note: The following procedures must be performed by an authorized Taylor service technician.

To correct the rotation on a three-phase unit, interchange any two incoming power supply lines at the freezer main terminal block only.

To correct rotation on a single-phase unit, change the leads inside the beater motor. (Follow the diagram printed on the motor.)

Electrical connections are made directly to the terminal block provided in the small junction box located behind the left side panel on the bottom of the frame.

Refrigerant



In consideration of our environment, Taylor proudly uses only earth friendly HFC refrigerants. The HFC refrigerant used in this unit is R404A. This refrigerant is generally considered non-toxic and non-flammable, with an Ozone Depleting Potential (ODP) of zero (0).

However, any gas under pressure is potentially hazardous and must be handled with caution.

NEVER fill any refrigerant cylinder completely with liquid. Filling the cylinder to approximately 80% will allow for normal expansion.



Refrigerant liquid sprayed onto the skin may cause serious damage to tissue. Keep eyes and skin protected. If refrigerant burns should occur, flush immediately with cold water. If burns are severe, apply ice packs and contact a physician immediately.



Taylor reminds technicians to be cautious of government laws regarding refrigerant recovery, recycling, and reclaiming systems. If you have any questions regarding these laws, please contact the factory Service Department.



WARNING: R404A refrigerant used in conjunction with polyolester oils is extremely moisture absorbent. When opening a refrigeration system, the maximum time the system is open must not exceed 15 minutes. Cap all open tubing to prevent humid air or water from being absorbed by the oil.

Section 2

To the Operator

Your freezers have been carefully engineered and manufactured to give you dependable operation. These units, when properly operated and cared for, will produce a consistent quality product. Like all mechanical products, they will require cleaning and maintenance. A minimum amount of care and attention is necessary if the operating procedures outlined in this manual are followed closely.

This Operator's Manual should be read before operating or performing any maintenance on your equipment.

Your Taylor freezer will NOT eventually compensate and correct for any errors during the set-up or filling operations. Thus, the initial assembly and priming procedures are of extreme importance. It is strongly recommended that all personnel responsible for the equipment's operation study these procedures together in order to be properly trained and to make sure that no misunderstandings exist.

In the event you should require technical assistance, please contact your local authorized Taylor Distributor.

Note: Warranty is valid only if the parts are authorized Taylor parts, purchased from an authorized Taylor Distributor, and the required service work is provided by an authorized Taylor service technician. Taylor reserves the right to deny warranty claims on equipment or parts if non-approved parts or refrigerant were installed in the machine, system modifications were performed beyond factory recommendations, or it is determined that the failure was caused by neglect or abuse.

Note: Constant research results in steady improvements; therefore, information in this manual is subject to change without notice.



If the crossed out wheeled bin symbol is affixed to this product, it signifies that this product is compliant with the EU Directive as well as other similar legislation in effect after August 13, 2005. Therefore, it must be collected separately after its use is completed, and cannot be disposed as unsorted municipal waste.

The user is responsible for returning the product to the appropriate collection facility, as specified by your local code.

For additional information regarding applicable local laws, please contact the municipal facility and/or local distributor.

Compressor Warranty Disclaimer

The refrigeration compressors on this machine are warranted for the term indicated on the warranty card accompanying this machine. However, due to the Montreal Protocol and the U.S. Clean Air Act Amendments of 1990, many new refrigerants are being tested and developed, thus seeking their way into the service industry. Some of these new refrigerants are being advertised as drop-in replacements for numerous applications. It should be noted that, in the event of ordinary service to this machine's refrigeration system, **only the refrigerant specified on the affixed data label should be used.** The unauthorized use of alternate refrigerants will void your compressor warranty. It will be the owner's responsibility to make this fact known to any technician he employs.

It should also be noted that Taylor does not warrant the refrigerant used in its equipment. For example, if the refrigerant is lost during the course of ordinary service to this machine, Taylor has no obligation to either supply or provide its replacement either at billable or unbillable terms. Taylor does have the obligation to recommend a suitable replacement if the original refrigerant is banned, obsoleted, or no longer available during the five year warranty of the compressor.

Taylor will continue to monitor the industry and test new alternates as they are being developed. Should a new alternate prove, through our testing, that it would be accepted as a drop-in replacement, then the above disclaimer would become null and void. To find out the current status of an alternate refrigerant as it relates to your compressor warranty, call the local Taylor Distributor or the Taylor Factory. Be prepared to provide the Model/Serial Number of the unit in question.

We, at Taylor Company, are concerned about the safety of the operator when he or she comes in contact with the freezer and its parts. Taylor has gone to extreme efforts to design and manufacture built-in safety features to protect both you and the service technician. As an example, warning labels have been attached to the freezer to further point out safety precautions to the operator.



IMPORTANT - Failure to adhere to the following safety precautions may result in severe personal injury or death. Failure to comply with these warnings may damage the machine and its components. Component damage will result in part replacement expense and service repair expense.



DO NOT operate the freezer without reading this Operator's Manual. Failure to follow this instruction may result in equipment damage, poor freezer performance, health hazards, or personal injury.

Per IEC 60335-1 and its part 2 standards, "This appliance is to be used only by trained personnel. It is not intended for use by children or people with reduced physical, sensory, or mental capabilities, or lack of experience and knowledge, unless given supervision or instruction concerning the use of the appliance by a person responsible for their safety."



This unit is provided with an equipotential grounding lug that is to be properly attached to the rear of the frame by the authorized installer. The installation location is marked by the equipotential bonding symbol (5021 of IEC 60417-1) on both the removable panel and the equipment's frame.



DO NOT use a water jet to clean or rinse the freezer. Failure to follow these instructions may result in serious electrical shock.



- **DO NOT** operate the freezer unless it is properly grounded.
- **DO NOT** operate the freezer with larger fuses than specified on the freezer data label.
- All repairs must be performed by an authorized Taylor service technician. The main power supplies to the machine must be disconnected prior to performing any repairs.
- Cord Connected Units: Only Taylor authorized service technicians may install a plug on this unit.
- Stationary appliances which are not equipped with a power cord and a plug or another device to disconnect the appliance from the power source must have an all-pole disconnecting device with a contact gap of at least 3 mm installed in the external installation.
- Appliances that are permanently connected to fixed wiring and for which leakage currents may exceed 10 mA, particularly when disconnected, not used for long periods, or during initial installation, shall have protective devices such as a GFI to protect against the leakage of current, installed by authorized personnel to the local codes.
- Supply cords used with this unit shall be oil-resistant, sheathed flexible cable, not lighter than ordinary polychloroprene or other equivalent synthetic elastomer-sheathed cord (Code designation 60245 IEC 57) installed with the proper cord anchorage to relieve conductors from strain, including twisting, at the terminals and protect the insulation of the conductors from abrasion.

Failure to follow these instructions may result in electrocution. Contact your local authorized Taylor Distributor for service.



- **DO NOT** allow untrained personnel to operate this machine.
- **DO NOT** operate the freezer unless all service panels and access doors are restrained with screws.
- **DO NOT** remove any internal operating parts (examples: freezer door, beater, scraper blades, etc.) unless all control switches are in the OFF position.

Failure to follow these instructions may result in severe personal injury to fingers or hands from hazardous moving parts.



This unit has many sharp edges that can cause severe injuries.

- **DO NOT** put objects or fingers in the door spout. This may contaminate the product and cause severe personal injury from blade contact.
- **USE EXTREME CAUTION** when removing the beater assembly. The scraper blades are very sharp.



This freezer must be placed on a level surface. Failure to comply may result in personal injury or equipment damage.



Cleaning and sanitizing schedules are governed by your state or local regulatory agencies and must be followed accordingly. Please refer to the cleaning section of this manual for the proper procedure to clean this unit.

DO NOT obstruct air intake and discharge openings:

Air cooled units require a minimum of 3" (76 mm) of clearance around all sides of the freezers and 3-1/2" (89 mm) on the bottom.

Model 359 only: Installation of air deflector is required.

Failure to allow adequate clearance can reduce the refrigeration capacity of the freezers and possibly cause permanent damage to the compressors.

For Indoor Use Only: This unit is designed to operate indoors, under normal ambient temperatures of 70° - 75°F (21° - 24°C). The freezer has successfully performed in high ambient temperatures of 104°F (40°C) at reduced capacities.

NOISE LEVEL: Airborne noise emission does not exceed 78 dB(A) when measured at a distance of 1.0 meter from the surface of the machine and at a height of 1.6 meters from the floor.

Section 4

Operator Parts Identification

Model 358

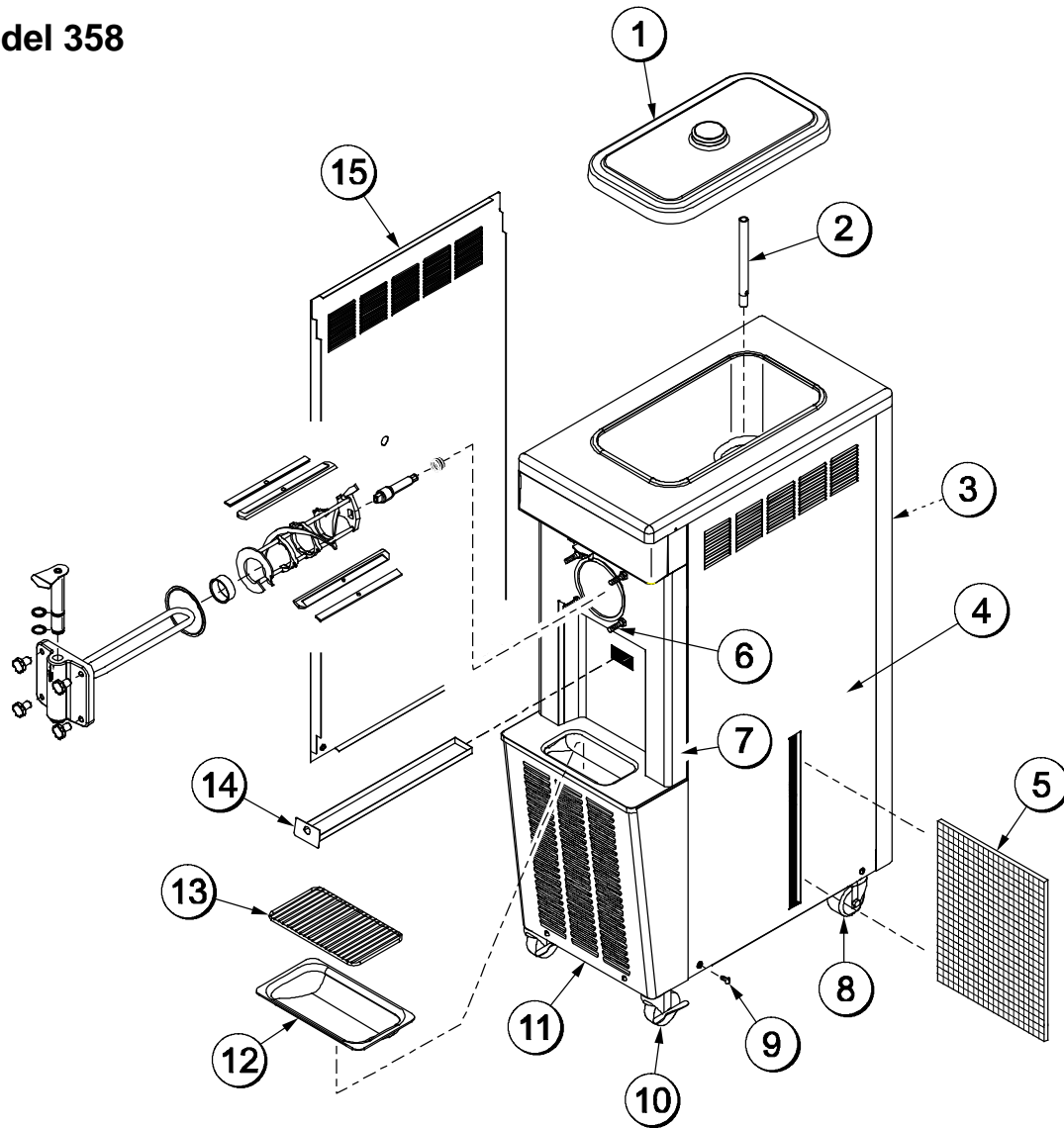

Figure 1

ITEM	DESCRIPTION	PART NO.
1	COVER A.-HOPPER INSUL	X51658
2	TUBE-FEED-NONREVERS	015176-5
3	PANEL-REAR	046021
4	PANEL-SIDE *358* RIGHT	046023-SP1
5	FILTER A.-13 X 16-7/8 X 7/16	046044
6	STUD-NOSE CONE	054748
7	CHANNEL A.-CONTROL	X63534
8	CASTER-SWIVEL 3/4 - 10 ST.	021279

ITEM	DESCRIPTION	PART NO.
9	SCREW-1/4-20 X 5/8 SLOTTED	005542
10	CASTER-LOCKING SWIVEL	030307
11	PANEL-SERVICE	048267
12	PAN A.-DRIP	X50879
13	SHIELD-SPLASH	066697
14	TRAY-DRIP	066696
15	PANEL-SIDE *358* LEFT	046022

Model 359

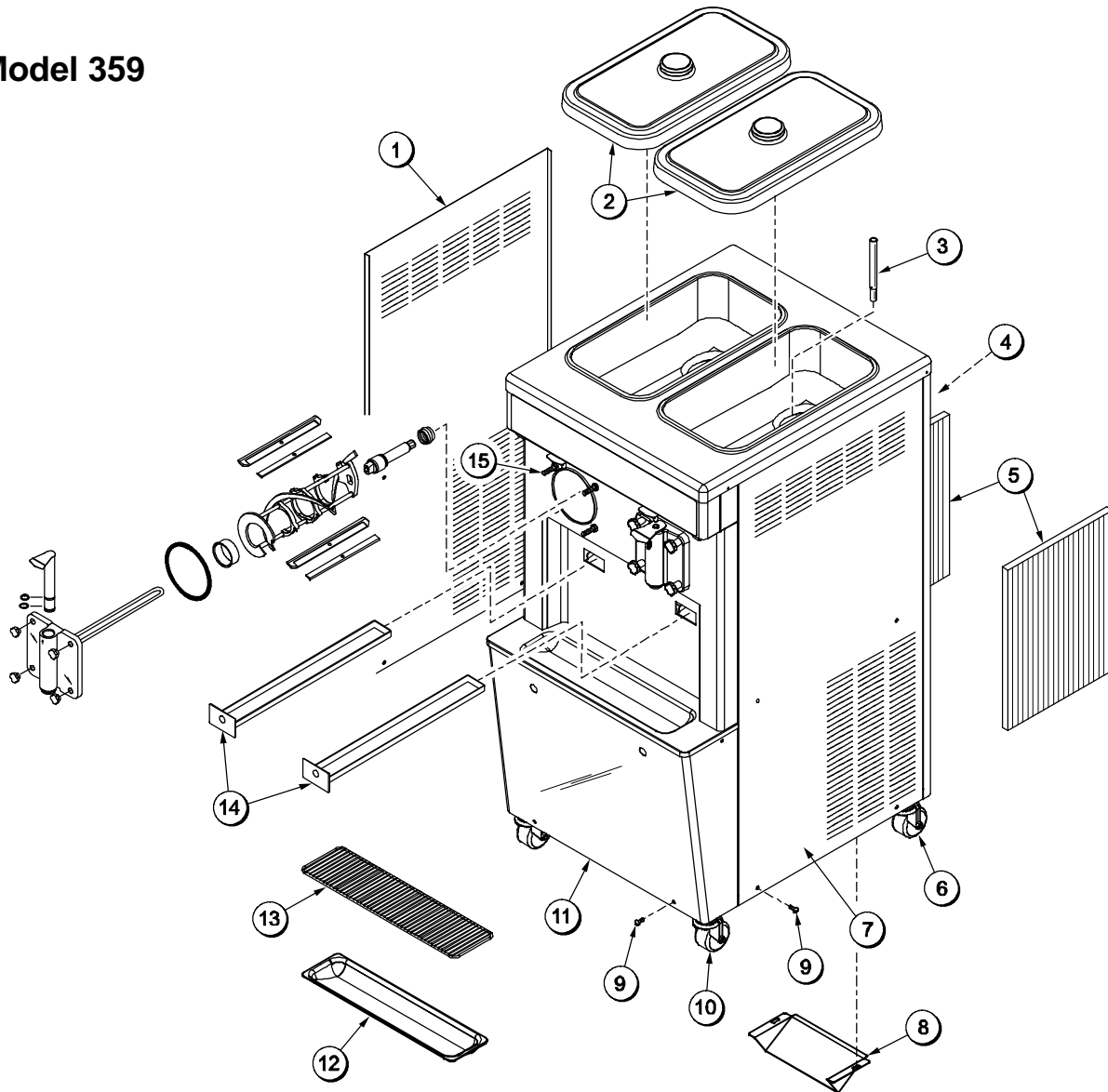

Figure 2

ITEM	DESCRIPTION	PART NO.
1	PANEL-SIDE-LEFT	065250
2	COVER ASSEMBLY-HOPPER	X51658
3	TUBE-FEED-NONREVERSIBLE	015176-5
4	PANEL-REAR	065271
5	FILTER-AIR 18 L X 13.5 H X .70	052779-3
6	CASTER-3" SWIVEL 3/4-10STM	021279
7	PANEL-SIDE-RIGHT	065251
8	DEFLECTOR-AIR	065200

ITEM	DESCRIPTION	PART NO.
9	SCREW-1/4-20 X 5/8 SLOTTED	005542
10	CASTER-3" SWV 3/4-10 LOCK	030307
11	PANEL-SERVICE FRONT	065268
12	TRAY-DRIP 19-5/8 L X 4-7/8	033812
13	SHIELD-SPLASH-WIRE	033813
14	PAN A.-DRIP	X50879
15	STUD-NOSE CONE	054748

Beater and Door Assembly

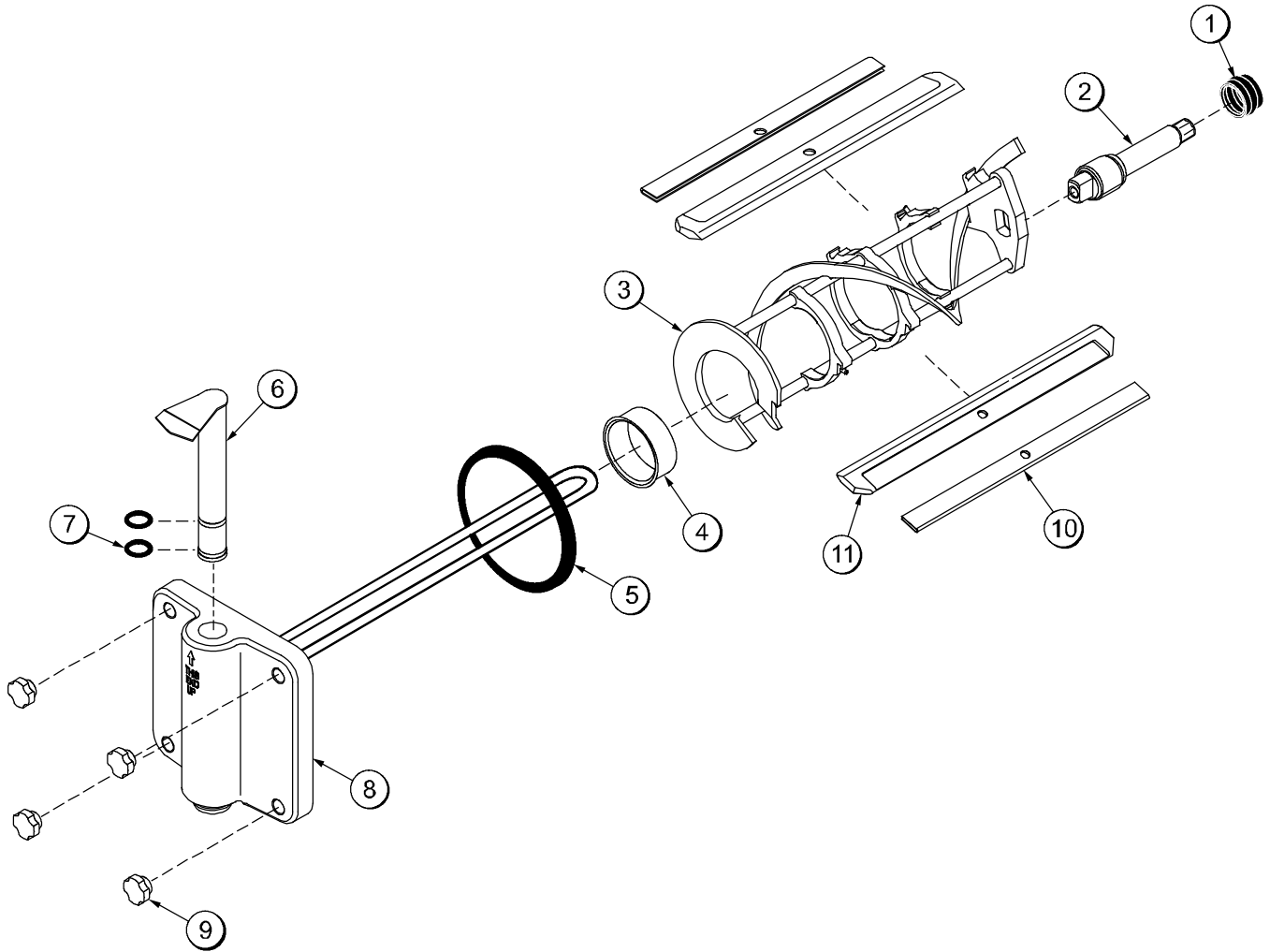

Figure 3

ITEM	DESCRIPTION	PART NO.
1	SEAL-DRIVE SHAFT	032560
2	SHAFT-BEATER	033235
3	BEATER A.-7 QT. - 1 PIN	X46233
4	BEARING-FRONT	013116
5	GASKET-DOOR - 5.177 ID X 5.9380	016672

ITEM	DESCRIPTION	PART NO.
6	VALVE A.-DRAW	X46028
7	O-RING - 1-1/16 OD x .139 W	020571
8	DOOR-PARTIAL 1 SPOUT	X30272-SER
9	NUT-STUD	021508
10	CLIP-SCRAPER BLADE 8.75"	046238
11	BLADE-SCRAPER PLASTIC	046237

Accessories

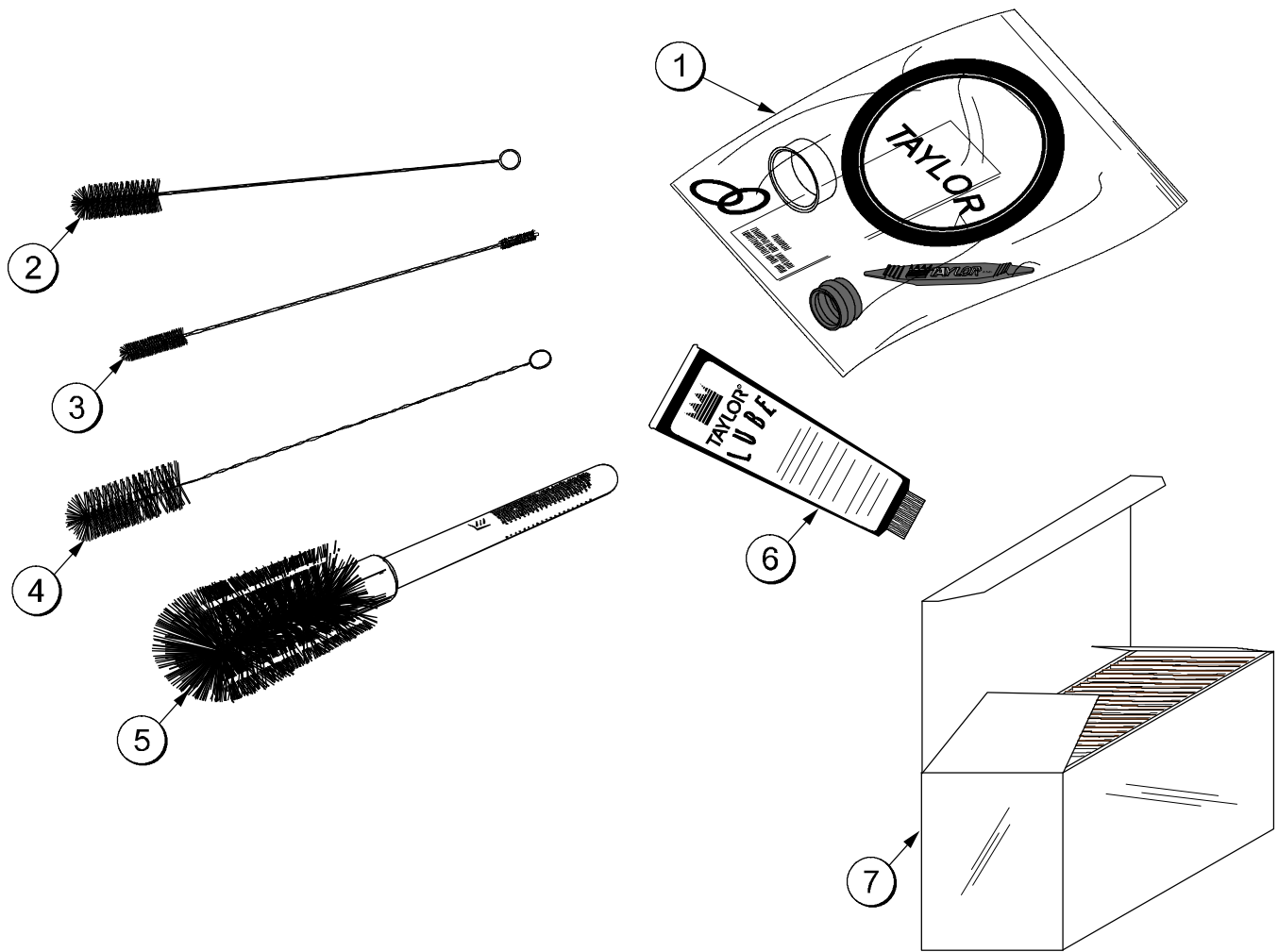

Figure 4

ITEM	DESCRIPTION	PART NO.
1	KIT ASSEMBLY-TUNE UP *358	X46050
	KIT ASSEMBLY-TUNE UP *359	X36356
2	BRUSH-REAR BEARING	013071
3	BRUSH-DOUBLE ENDED	013072

ITEM	DESCRIPTION	PART NO.
4	BRUSH-DRAW VALVE	014753
5	BRUSH-HOPPER 3" x 7"	023316
6	LUBRICANT-TAYLOR 4 OZ.	047518
*7	SANITIZER-STERA-SHEEN	SEE NOTE

***Note:** A sample container of sanitizer is sent with the unit. For reorders, order Stera Sheen part no. 055492 (100 packs) or Kay-5 part no. 041082 (125 packs).

Section 5

Important: To the Operator

Model 358

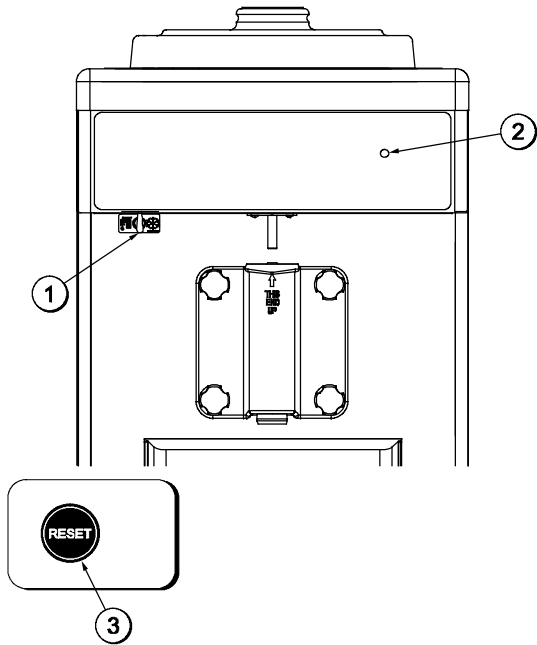

Figure 5

ITEM	DESCRIPTION
1	POWER SWITCH
2	MIX OUT INDICATOR
3	RESET BUTTON

Model 359

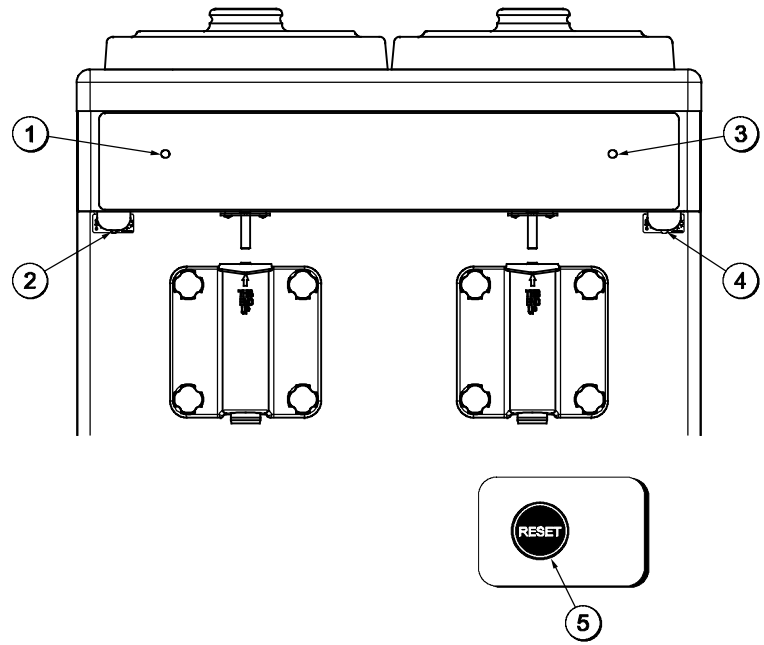

Figure 6

ITEM	DESCRIPTION
1	MIX OUT INDICATOR-LEFT SIDE
2	POWER SWITCH-LEFT SIDE
3	MIX OUT INDICATOR-RIGHT SIDE
4	POWER SWITCH-RIGHT SIDE
5	RESET BUTTON

Power Switch

The middle position is “OFF”. The left position is “WASH”, which activates the beater motor only. The right position is “AUTO”, which activates the beater motor and the refrigeration system.

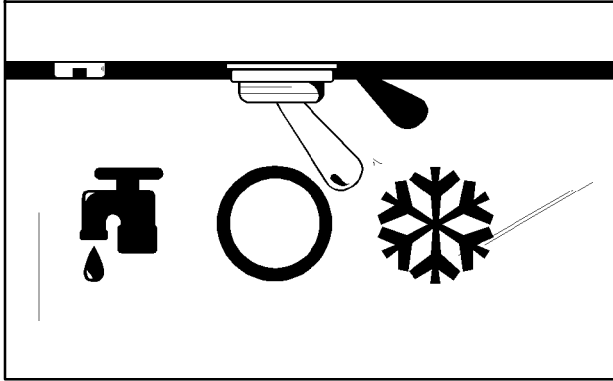

Figure 7

Indicator Light - “Mix Out”

The “MIX OUT” light is located on the front of the machine. When the “MIX OUT” light begins to flash, the mix hopper has been almost completely exhausted and has an insufficient supply of mix to operate the freezer. Only a small amount of mix (less than 1 pint) is left in the hopper.

At this time the “AUTO” mode is locked out and the freezer shuts down, protecting the freezer from costly damage due to a freeze-up. To initiate the refrigeration system, add mix to the mix hopper. The freezer will automatically begin operation.

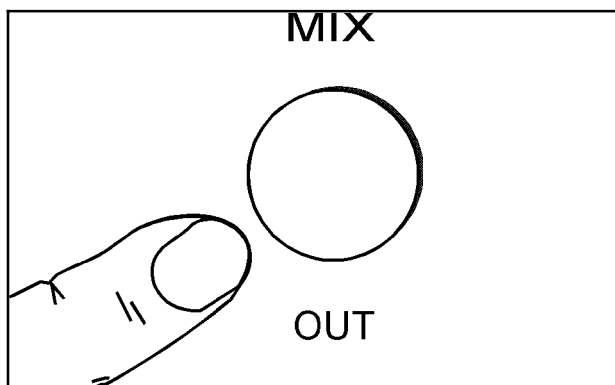

Figure 8

Reset Button



Note: Do not use metal objects to press the reset button. Failure to follow this instruction may result in serious electrical shock.

The reset button is located in the left side panel on the Model 358. The reset buttons are located in the lower front panel on the Model 359. The reset mechanism protects the beater motor from an overload condition. Should an overload occur, the reset mechanism will trip.

To properly reset the freezer, place the power switch in the “OFF” position. Press the reset button firmly. Place the power switch in the “WASH” position and observe the freezer's performance. Open the side access panel to check if the beater motor is turning the drive shaft in a clockwise (from operator end) direction without binding.

If it is turning properly, place the power switch in the “AUTO” position to resume normal operation. If the freezer shuts down again, contact a service technician.

Air Tube

The air tube is designed with a hole on one end. After priming the machine, install the air tube into the mix inlet hole with the hole end down. Every time the draw handle is raised, new mix and air from the hopper will flow down into the freezing cylinder. This will keep the freezing cylinder properly loaded and maintain overrun.

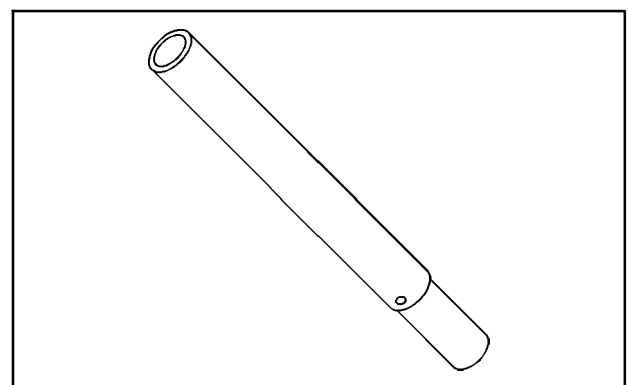

Figure 9

Section 6

Operating Procedures

The Model 358 has been selected to show you the pictured step-by-step operating procedures for both models contained in this manual. These models, for practical purposes of operation, are the same.

These models store 20 quarts (18.9 liters) of mix in each hopper. The mix flows by **gravity** from the hopper to the freezing cylinder through an air tube.

We begin our instructions at the point where we enter the store in the morning and find the parts disassembled and laid out to air dry from the previous night's cleaning.

These opening procedures will show you how to assemble these parts into the freezer, sanitize them, and prime the freezer with fresh mix in preparation to serve your first portion.

If you are disassembling the machine for the first time or need information to get to this starting point in our instructions, turn to page 19 "Disassembly", and start there.

Assembly

Note: When lubricating parts, use an approved food grade lubricant (example: Taylor Lube).



MAKE SURE THE POWER SWITCH IS IN THE "OFF" POSITION. Failure to do so may cause injury from hazardous moving parts, or electrocution.

Step 1

Lubricate the groove and shaft portion that comes in contact with the bearing on the beater drive shaft. Slide the seal over the shaft and groove until it snaps into place. **DO NOT** lubricate the hex end of the drive shaft. Fill the inside portion of the seal with 1/4" more lubricant and lubricate the flat side of the seal that fits onto the rear shell bearing.

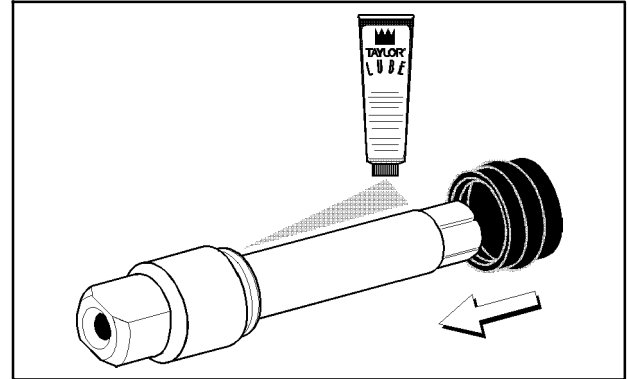

Figure 10

Step 2

Install the drive shaft into the freezing cylinder, hex end first, and into the rear shell bearing until the seal fits securely over the rear shell bearing. Engage the hex end firmly into the drive coupling. Be sure the drive shaft fits into the drive coupling without binding.

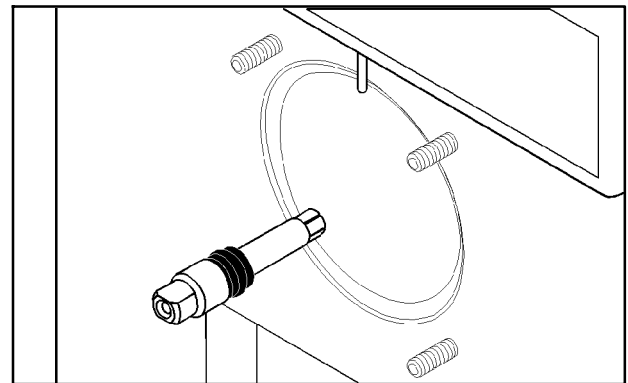

Figure 11

Step 3

Check the scraper blades for any nicks or signs of wear. If any nicks are present, replace both blades. If the blades are in good condition, install the scraper blade clips on the scraper blades. Place the rear scraper blade over the rear holding pin on the beater assembly.

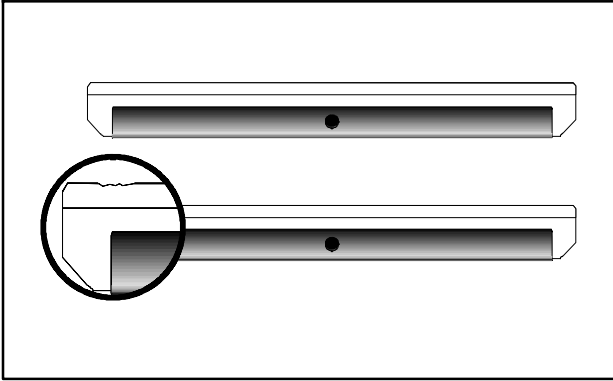

Figure 12

Note: The hole on the scraper blade must fit securely over the pin to prevent costly damage.

Step 4

Holding the rear blade on the beater, slide the beater halfway into the freezing cylinder. Install the front scraper blade over the front holding pin. Slide the beater assembly the rest of the way into the freezing cylinder.

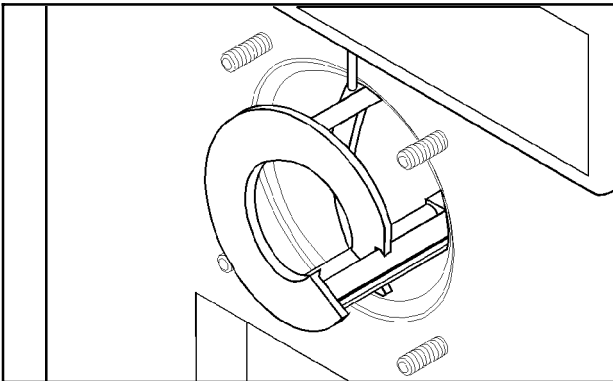

Figure 13

Step 5

Make sure the beater assembly is in position over the drive shaft. Turn the beater slightly to be certain the beater is properly seated. When in position, the beater will not protrude beyond the front of the freezing cylinder.

Step 6

Slide the two o-rings into the grooves on the draw valve and lubricate.

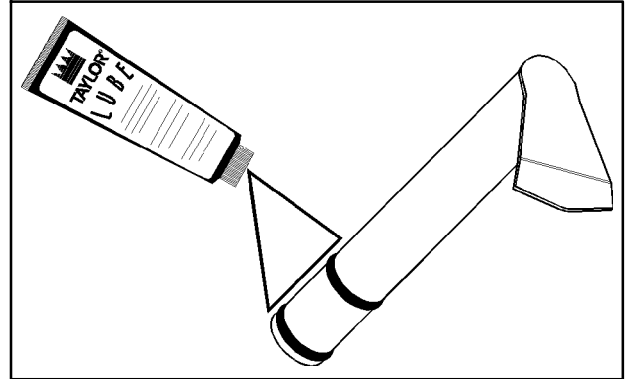

Figure 14

Step 7

Lubricate the inside of the freezer door spout, top and bottom, and insert the draw valve into the freezer door from the top ("THIS END UP").

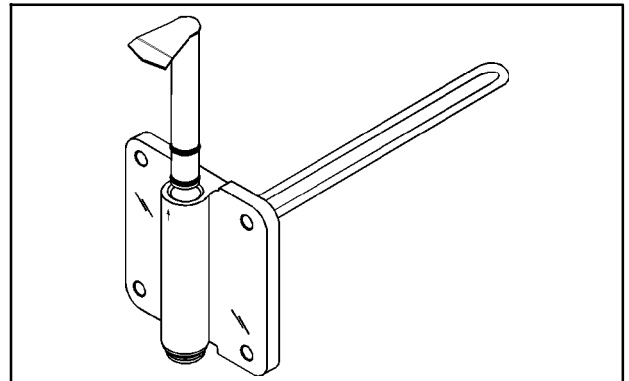

Figure 15

Step 8

Place the freezer door gasket into the groove on the back of the freezer door. Slide the white plastic front bearing over the baffle rod onto the bearing hub, making certain the flanged end of the bearing is resting against the freezer door. **DO NOT LUBRICATE THE GASKET OR THE FRONT BEARING.**

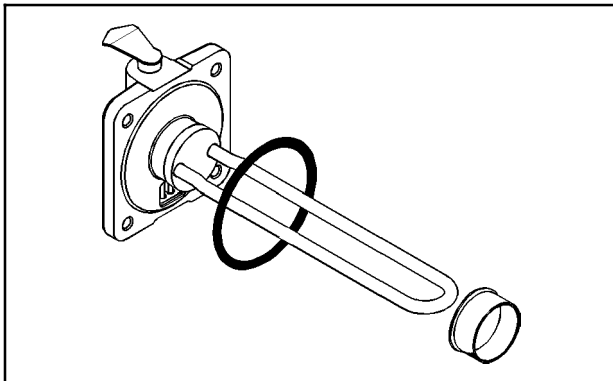

Figure 16

Step 9

Insert the baffle rod through the opening in the beater and set the door flush with the freezing cylinder. With the door seated on the freezer studs, install the handscrews. Tighten the handscrews equally in a criss-cross pattern to insure the door is snug.

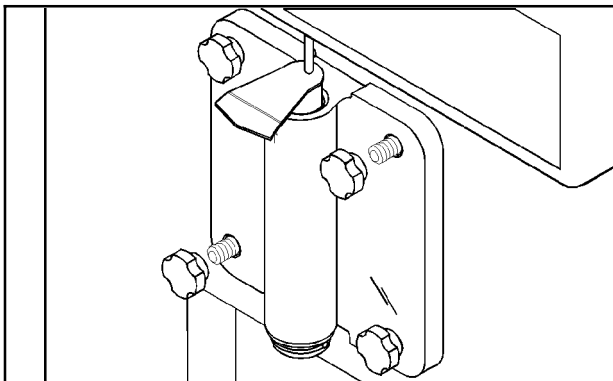

Figure 17

Step 10

Lay the air tube in the bottom of the mix hopper for sanitizing.

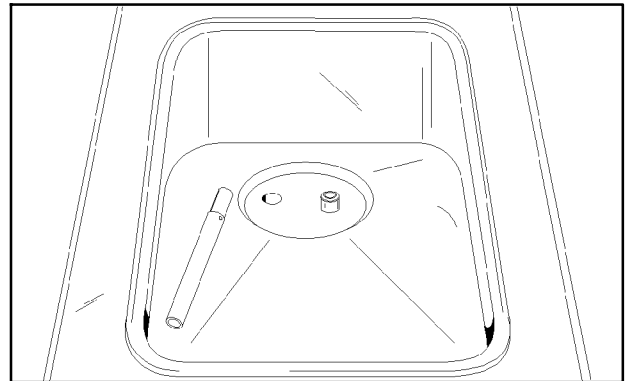

Figure 18

Step 11

Slide the drive shaft drip pan into the hole in the front panel.

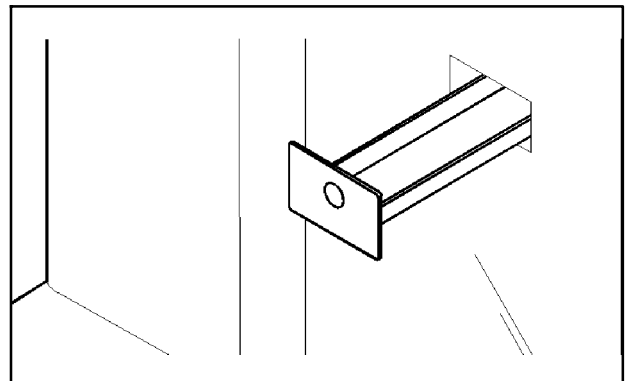

Figure 19

Repeat Steps 1 through 11 for the other side of the freezer on the Model 359.

Step 12

Install the front drip tray and splash shield under the door spout.

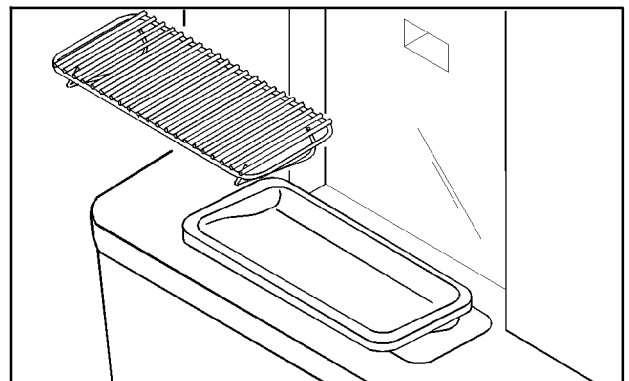

Figure 20

Sanitizing

Step 1

Prepare an approved 100 PPM sanitizing solution (examples: 2-1/2 gal. [9.5 liters] of Kay-5® or 2 gal. [7.6 liters] of Stera-Sheen®). **USE WARM WATER AND FOLLOW THE MANUFACTURER'S SPECIFICATIONS.**

Step 2

Pour the sanitizing solution into the hopper and allow it to flow into the freezing cylinder.

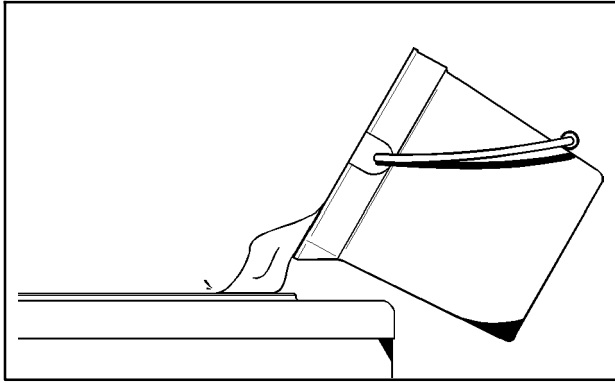

Figure 21

Step 3

While the solution is flowing into the freezing cylinder, brush clean the mix hopper. In cleaning the hopper, take particular care in brushing the mix level sensing probe, the mix inlet hole and the air tube.

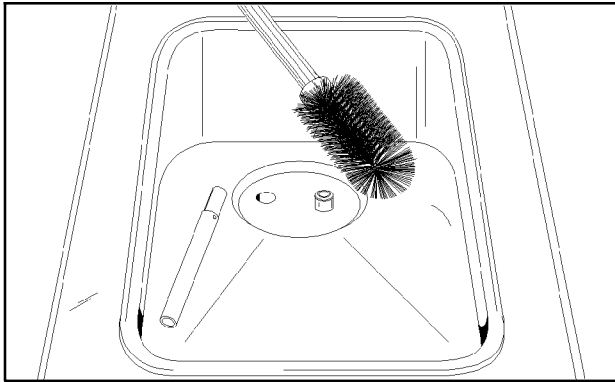

Figure 22

Step 4

Place the power switch in the "WASH" position. This will cause the sanitizing solution in the freezing cylinder to be agitated. Allow it to agitate for five minutes.

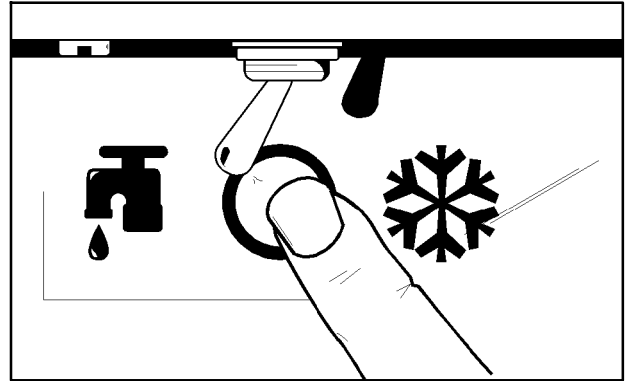

Figure 23

Step 5

Place an empty pail beneath the door spout and raise the draw handle. Draw off all the sanitizing solution. When the sanitizer stops flowing from the door spout, lower the draw handle and place the power switch in the "OFF" position.

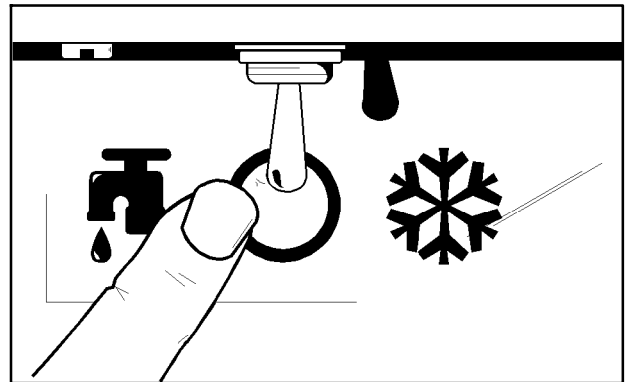

Figure 24



Note: You have just sanitized the freezer. **Be sure your hands are sanitized** before going on in these instructions.

Step 6

Stand the air tube in the corner of the mix hopper.

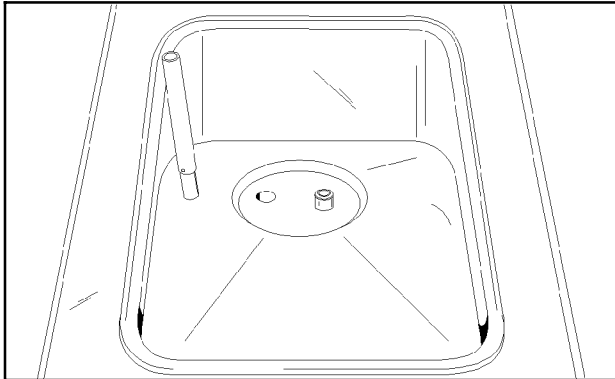

Figure 25

Repeat Steps 1 through 6 for the other side of the freezer on the Model 359.

Priming

Step 1

With a pail beneath the door spout, raise the draw handle. Pour **two** gallons (7.6 liters) of **fresh** mix into the mix hopper and allow it to flow into the freezing cylinder. This will force out any remaining sanitizing solution. When full strength mix is flowing from the door spout, lower the draw handle.

Note: Use only **fresh** mix when priming the freezer.

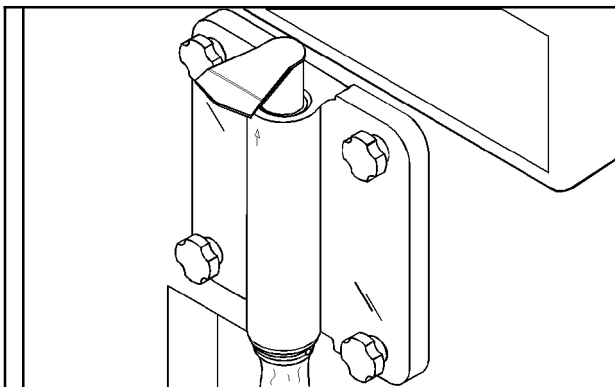

Figure 26

Step 2

When the mix stops bubbling down into the freezing cylinder, install the air tube in the mix inlet hole.

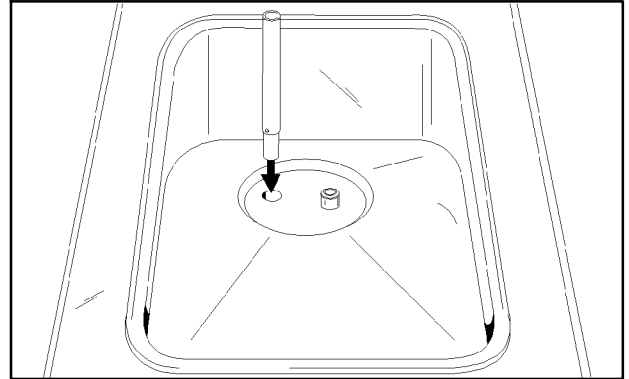

Figure 27

Step 3

Place the power switch in the "AUTO" position. Raise the draw switch to activate the refrigeration system. When the unit cycles off, the product will be at serving viscosity.

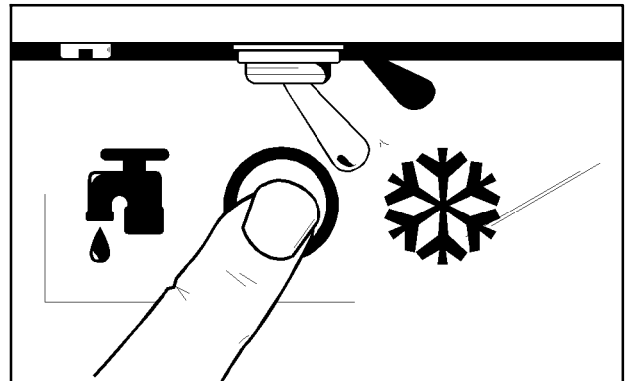

Figure 28

Step 4

Fill the hopper with fresh mix.

Step 5

Place the mix hopper cover in position over the mix hopper.

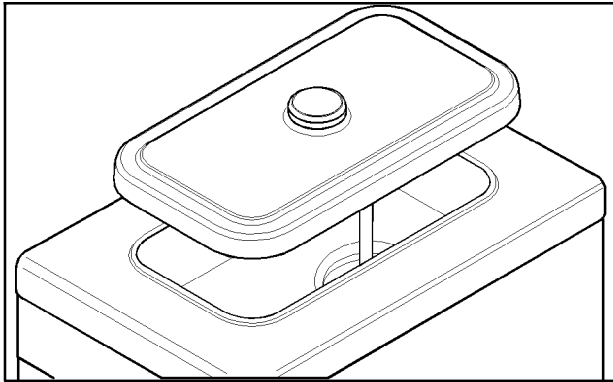

Figure 29

Repeat Steps 1 through 5 for the other side of the freezer on the Model 359.

Closing Procedure

To disassemble your unit, the following items will be needed:

- Two cleaning pails
- Sanitized NSF approved stainless steel rerun can(s) with lid(s)
- Necessary brushes (provided with freezer)
- Cleaner
- Single service towels

Draining Product From the Freezing Cylinder

Step 1

Remove the hopper cover and the air tube. Take them to the sink for cleaning.

Step 2

If local health codes permit the use of rerun, place a sanitized, NSF approved stainless steel rerun container beneath the door spout. Place the power switch in the “WASH” position. Raise the draw handle and drain the remaining product from the freezing cylinder and the mix hopper. When the flow of product stops, place the power switch in the “OFF” position and lower the draw handle. Place a sanitized lid on the rerun container and place it in the walk-in cooler.

Note: For additional information regarding the proper use of rerun, see item 5 on page 21.

Note: If local health codes DO NOT permit the use of rerun, the product must be discarded. Follow the instructions in the previous step, except drain the product into a mix pail and properly discard the mix.



ALWAYS FOLLOW LOCAL HEALTH CODES.

Repeat Steps 1 through 2 for the other side of the freezer on the Model 359.

Rinsing

Step 1

Pour two gallons (7.6 liters) of **cool** clean water into the mix hopper. With the brushes provided, scrub the mix hopper, the mix level sensing probe and the mix inlet hole.

Step 2

With a pail beneath the door spout, place the power switch in the “WASH” position and raise the draw handle. Drain all the rinse water from the freezing cylinder and the mix hopper. When the rinse water stops flowing from the door spout, lower the draw handle and place the power switch in the “OFF” position.

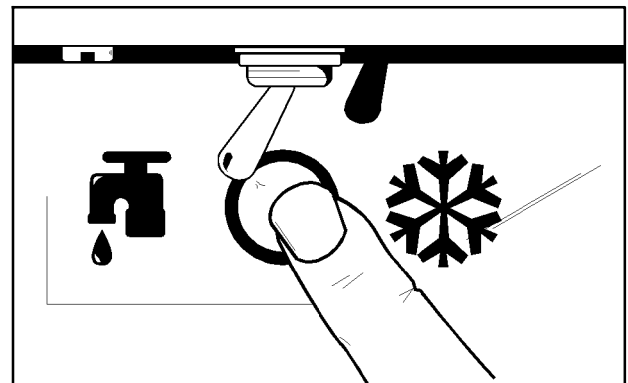

Figure 30

Repeat these procedures until the rinse water being drawn from the freezing cylinder is clear.

Repeat Steps 1 through 2 for the other side of the freezer on the Model 359.

Cleaning

Step 1

Prepare an approved 100 PPM cleaning solution (examples: 2-1/2 gal. [9.5 liters] of Kay-5® or 2 gal. [7.6 liters] of Stera-Sheen®). USE WARM WATER AND FOLLOW THE MANUFACTURER'S SPECIFICATIONS.

Step 2

Pour the cleaning solution into the mix hopper.

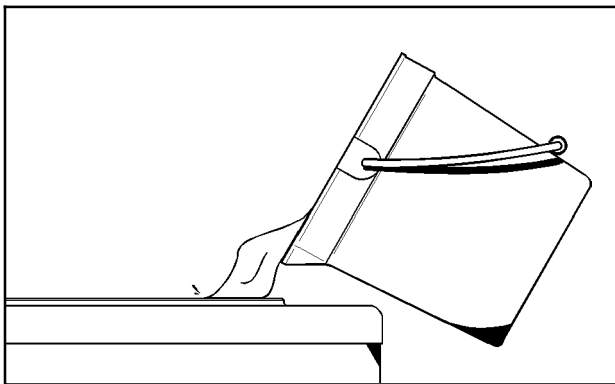

Figure 31

Step 3

While the solution is flowing into the freezing cylinder, brush clean the mix hopper, the mix level sensing probe and the mix inlet hole.

Step 4

Place the power switch in the "WASH" position. This will cause the cleaning solution in the freezing cylinder to be agitated.

Step 5

Place an empty pail beneath the door spout and raise the draw handle. Draw off all the cleaning solution. When the solution stops flowing from the door spout, lower the draw handle and place the power switch in the "OFF" position.

Repeat Steps 1 through 5 for the other side of the freezer on the Model 359.

Disassembly



MAKE SURE THE POWER SWITCH IS IN THE "OFF" POSITION. Failure to do so may cause injury from hazardous moving parts or electrocution.

Step 1

Remove the freezer door, beater, scraper blades, and the drive shaft from the freezing cylinder. Take them to the sink for cleaning.

Repeat for the other side of the freezer on the Model 359.

Step 2

Remove the front drip tray and the splash shield.

Brush Cleaning

Step 1

Prepare a sink with an approved cleaning solution (example: Kay-5® or Stera-Sheen®). USE WARM WATER AND FOLLOW THE MANUFACTURER'S SPECIFICATIONS

IMPORTANT: Follow label directions, as too STRONG of a solution can cause parts damage, while too MILD of a solution will not provide adequate cleaning. Make sure all brushes provided with the freezer are available for brush cleaning.

Step 2

Remove the seal(s) from the drive shaft(s).

Step 3

Remove the scraper blade clips from the scraper blades.

Step 4

From the freezer door(s) remove:

- gasket(s)
- front bearing(s)
- draw valve(s)

Remove all o-rings.

Note: To remove o-rings, use a single service towel to grasp the o-ring. Apply pressure in an upward direction until the o-ring pops out of its groove. With the other hand, push the top of the o-ring forward. It will roll out of the groove and can be easily removed. If there is more than one o-ring to be removed, always remove the rear o-ring first. This will allow the o-ring to slide over the forward rings without falling into the open grooves.

Step 5

Return to the freezer with a small amount of cleaning solution. With the black bristle brush, brush clean the rear shell bearing(s) at the back of the freezing cylinder(s).

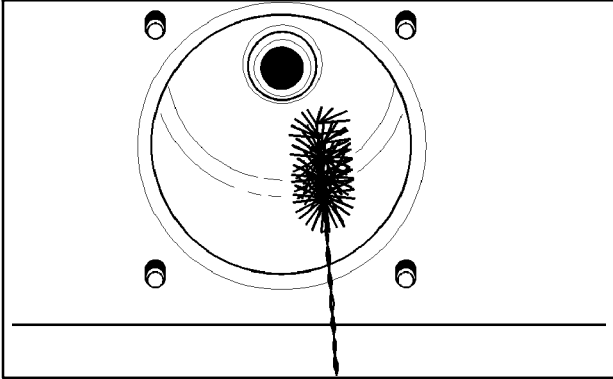

Figure 32

Step 6

Remove the drive shaft drip pan(s) from the front panel and take to the sink for cleaning.

Note: If the drive shaft drip pan is filled with an excessive amount of mix, refer to the Troubleshooting Guide.

Step 7

Thoroughly brush clean all disassembled parts in the cleaning solution, making sure all lubricant and mix film is removed. Take particular care to brush clean the draw valve core in the freezer door. Place all the cleaned parts on a clean dry surface to air dry overnight.

Step 8

Wipe clean all exterior surfaces of the freezer.

Section 7 Important: Operator Checklist

During Cleaning and Sanitizing



ALWAYS FOLLOW LOCAL HEALTH CODES.

Cleaning and sanitizing schedules are governed by federal, state, or local regulatory agencies, and must be followed accordingly. If the unit has a “Standby mode”, it must not be used in lieu of proper cleaning and sanitizing procedures and frequencies set forth by the ruling health authority. The following check points should be stressed during the cleaning and sanitizing operations.



CLEANING AND SANITIZING MUST BE PERFORMED DAILY.

Troubleshooting Bacterial Count

- 1. Thoroughly clean and sanitize the machine regularly, including complete disassembly and brush cleaning.
- 2. Use all brushes supplied for thorough cleaning. The brushes are specially designed to reach all mix passageways.
- 3. Use the white bristle brush to clean the mix inlet hole which extends from the mix hopper down to the rear of the freezing cylinder.
- 4. Use the black bristle brush to thoroughly clean the rear shell bearing located at the rear of the freezing cylinder. Be sure there is a generous amount of cleaning solution on the brush.

- 5. IF LOCAL HEALTH CODES PERMIT THE USE OF RERUN, make sure the mix rerun is stored in a sanitized, covered, NSF approved stainless steel rerun container and used the following day. DO NOT prime the machine with rerun. When using rerun, skim off the foam and discard; then mix the rerun with fresh mix in a ratio of 50/50 during the day's operation.
- 6. On a designated day of the week, run the mix as low as feasible and discard after closing. This will break the rerun cycle and reduce the possibility of high bacteria and coliform counts.
- 7. Properly prepare the cleaning and sanitizing solutions. Read and follow the label directions carefully. Too strong of a solution may damage the parts and too weak of a solution will not do an adequate job of cleaning or sanitizing.
- 8. The temperature of the mix in the mix hopper and walk-in cooler should be below 40°F. (4.4°C.).

Regular Maintenance Checks

- 1. Replace scraper blades that are nicked or damaged. Before installing the beater, be certain that the scraper blades are properly attached.
- 2. Check the rear shell bearing for signs of wear (excessive mix leakage in the drive shaft drip pan) and be certain it is properly cleaned.
- 3. Using a screwdriver and cloth towel, keep the rear shell bearing and the female hex drive socket clean and free of lubricant and mix deposits.

- 4. Dispose of o-rings and seals if they are worn, torn, or fit too loosely, and replace with new ones.
- 5. Follow all lubricating procedures as outlined in “Assembly”.
- 6. If your machine is air cooled, check the condenser for accumulation of dirt and lint. Dirty condensers will reduce the efficiency and capacity of the machine. Condensers should be cleaned **monthly** with a soft brush. **Never use screwdrivers or other metal probes to clean between the fins.**

Note: For machines equipped with an air filter, it will be necessary to vacuum clean the filters on a monthly schedule.



CAUTION: Always disconnect electrical power prior to cleaning the condenser. Failure to follow this instruction may result in electrocution.

Winter Storage

If the place of business is to be closed during the winter months, it is important to protect the freezer by following certain precautions, particularly if the building is subject to freezing conditions.

Disconnect the freezer from the main power source to prevent possible electrical damage.

On water cooled freezers, disconnect the water supply. Use air pressure to blow out any water remaining in the condensers. **This is extremely important.** Failure to follow this procedure may cause severe and costly damage to the refrigeration system.

Your local Taylor Distributor can perform this service for you.

Wrap detachable parts of the freezer such as beater, blades, drive shaft, and freezer door. Place these parts in a protected, dry place. Rubber trim parts and gaskets can be protected by wrapping them with moisture-proof paper. All parts should be thoroughly cleaned of dried mix or lubrication, which attract mice and other vermin.

Section 8

Troubleshooting Guide

PROBLEM	PROBABLE CAUSE	REMEDY	PAGE REF.
1. No product is being dispensed with draw valve open and machine in the "AUTO" mode.	a. Beater motor is out on reset.	a. Reset the freezer.	12
	b. Circuit breaker off or blown fuse.	b. Turn breaker on or replace fuse.	--
	c. Inadequate mix in the mix hopper.	c. Fill the mix hopper with mix.	17
	d. Freeze-up in mix inlet hole.	d. Contact an authorized service technician to adjust the mix hopper temperature.	--
	e. Beater is rotating counterclockwise (from operator end).	e. Contact an authorized service technician to correct rotation to clockwise.	--
2. The product is too stiff.	a. Inadequate mix in hopper.	a. Fill the hopper with mix.	17
	b. Thermistor control is set too cold.	b. Contact an authorized service technician.	--
3. The product is too soft.	a. Worn scraper blades.	a. Replace regularly.	26
	b. Not enough air space is around the unit.	b. Allow for adequate air flow across the condenser.	1
	c. Dirty condenser.	c. Clean monthly.	22
	d. Out-of-date mix.	d. Use only fresh mix.	--
	e. Thermistor control is set too warm.	e. Contact an authorized service technician.	--
4. The mix in the mix hopper is too cold.	a. The temperature is out of adjustment.	a. Contact an authorized service technician.	--
5. The mix in the mix hopper is too warm.	a. The mix hopper cover is not in position.	a. Place the hopper cover in position.	18
	b. Warm mix was placed in the hopper.	b. Mix should be below 40°F (4.4°C) when placed in hopper.	21
	c. The temperature is out of adjustment.	c. Contact an authorized service technician.	--

PROBLEM	PROBABLE CAUSE	REMEDY	PAGE REF.
6. The drive shaft is stuck in the drive coupling.	<ul style="list-style-type: none"> a. Mix and lubricant collected in the drive coupling. b. Rounded corners of drive shaft, coupling or both. 	<ul style="list-style-type: none"> a. Brush clean the rear shell bearing area regularly. b. Call an authorized service technician to correct the cause and replace the necessary components. Do not lubricate the hex end of the drive shaft. 	<p>20</p> <p>--</p>
7. The freezing cylinder walls are scored.	<ul style="list-style-type: none"> a. Missing or worn front bearing on freezer door. b. The beater assembly is bent. 	<ul style="list-style-type: none"> a. Install or replace the front bearing. b. Call an authorized service technician to repair or replace the beater and to correct the cause of insufficient mix in freezing cylinder. 	<p>15 / 26</p> <p>--</p>
8. Excessive mix leakage into the drive shaft drip pan.	<ul style="list-style-type: none"> a. Missing or worn drive shaft seal on drive shaft. b. The drive shaft seal is installed inside out. c. Lack of lubrication. d. Worn rear shell bearing. 	<ul style="list-style-type: none"> a. Install or replace regularly. b. Install the seal properly. c. Lubricate properly. d. Contact an authorized service technician to replace the rear shell bearing. 	<p>13 / 26</p> <p>13</p> <p>13</p> <p>--</p>
9. Excessive mix leakage from the door spout.	<ul style="list-style-type: none"> a. Missing or worn draw valve o-rings. b. Inadequate lubrication of draw valve o-rings. c. Wrong type of lubricant is being used (example: petroleum base lubricant). 	<ul style="list-style-type: none"> a. Install or replace regularly. b. Lubricate properly. c. Use proper lubricant (example: Taylor Lube). 	<p>14 / 26</p> <p>14</p> <p>13</p>
10. No freezer operation after placing the unit in "AUTO".	<ul style="list-style-type: none"> a. The unit is unplugged. b. There is no mix in the mix hopper. c. Circuit breaker off or blown fuse. d. Beater motor out on reset. 	<ul style="list-style-type: none"> a. Plug into wall receptacle. b. Fill the mix hopper with mix. c. Turn breaker on or replace fuse. d. Reset the freezer. 	<p>--</p> <p>17</p> <p>--</p> <p>12</p>

PROBLEM	PROBABLE CAUSE	REMEDY	PAGE REF.
11. Product is not feeding into the freezing cylinder.	<ul style="list-style-type: none"> a. Inadequate level of mix in the mix hopper. b. Mix inlet hole frozen up. 	<ul style="list-style-type: none"> a. Fill the mix hopper with mix. b. Mix hopper temperature needs adjustment. Contact an authorized service technician. 	<p style="text-align: center;">17</p> <p style="text-align: center;">--</p>

Section 9

Parts Replacement Schedule

PART DESCRIPTION	EVERY 3 MONTHS	EVERY 4 MONTHS	EVERY 6 MONTHS	ANNUALLY	358 QTY.	359 QTY.
Drive Shaft Seal	X				1	2
Scraper Blade		X			2	4
Freezer Door Gasket	X				1	2
Front Bearing	X				1	2
Draw Valve O-Ring	X				2	4
Black Bristle Brush, 1" x 2"			Inspect & Replace if Necessary	Minimum	1	1
Double Ended Brush			Inspect & Replace if Necessary	Minimum	1	1
White Bristle Brush, 1" x 2"			Inspect & Replace if Necessary	Minimum	1	1
White Bristle Brush, 3" x 7"			Inspect & Replace if Necessary	Minimum	1	1

Section 10

Parts List

DESCRIPTION	PART NUMBER	QTY. 358	QTY. 359	WARR. CLASS	REMARKS
ARM A.-IDLER *356*	X64892	1	2	103	
+ BRACKET-IDLER ARM	045912	1	2	103	
+ BOLT-IDLER PULLEY *358*	046039	1	2	103	
+ SCREW-SHOULDER	046048	1	2	000	
+ SPRING-EXTENSION.500X.063X4.00	046046	1	2	103	
BEARING-FRONT	013116	1	2	000	
BEARING-REAR SHELL *NICK.PLATE	031324	1	2	000	
+ GUIDE-DRIP SEAL	028992	1	2	000	
+ NUT-BRASS BEARING	028991	1	2	000	
+ O-RING-1/2OD X .070W	024278	2	4	000	
+ WASHER-BEARING LOCK	012864	1	2	000	
BEARING-UNIT REAR	025629	1	2	103	DIRECT DRIVE UNIT
BEATER A.-7QT-1 PIN-SUPPORT	X46233	1	2	103	
+ BLADE-SCRAPER-PLASTIC 9-13/16L	046237	2	4	000	
+ CLIP-SCRAPER BLADE*8.75 INCH*	046238	2	4	103	
BELT-POLY V-450J10	044056	1	2	000	
BLOCK-TERMINAL 2P L1,L2	039422	1		103	208-230V 60HZ 1PH
BLOCK-TERMINAL 3P-L1 ,L2,L3	039423	1	1	103	208-230V 60HZ 3PH
BLOWER A.	X53725-27		1	103	
BOOT-CAPACITOR-INSULATING	031314		1	000	
CAPACITOR-RUN 7.5UF/370V	034749		1	103	
MOTOR-FAN 208-230V 50/60 HZ	053481-27		1	103	
SCREEN-BLOWER	053729		1	103	
BRUSH-DOUBLE ENDED-PUMP&FEED	013072	1	1	000	
BRUSH-DRAW VALVE 1-1/2"OD X 3"	014753	1	1	000	
BRUSH-MIX PUMP BODY-3"X7"WHITE	023316	1	1	000	
BRUSH-REAR BRG 1IN.DX2IN.LGX14	013071	1	1	000	
BUSHING-SNAP 11/16 ID X 7/8OD	010548	1	8	103	
BUSHING-PANEL	013289	4		103	
CAPACITOR-RUN- 4UF-440V	051785	1		103	CONDENSER FAN

DESCRIPTION	PART NUMBER	QTY. 358	QTY. 359	WARR. CLASS	REMARKS
CAPACITOR-RUN 7.5UF/370V	034749		1	103	BLOWER FAN
CASTER-LOCKING SWIVEL 3 IN.	030307	2	2	103	
CASTER-SWV-3/4-10 ST. 3IN WHL	021279	2	2	103	
COMPRESSOR CS18K6E	052397-27E	1		512	208-230V 60HZ 1PH - K0078823/UP COPELAWELD
+ CAPACITOR-START-189-227UF/250 V	053106	1		103	208-230V 60HZ 1PH
+ CAPACITOR-RUN- 35UF/440V	048132	1		103	208-230V 60HZ 1PH
+ RELAY-START-COMPRESSOR	051957-27	1		103	208-230V 60HZ 1PH
+ KIT-MOUNTING COMPRESSOR	052197	1		000	
COMPRESSOR CS18K6E-TF5-238	052397-33	1	2	512	208-230V 60HZ 3PH
CONDENSER-AC-12LX18HX4.3-5ROW	019558	1		103	
CONDENSER-AC 12LX18HX3.12T-5RW	055813-1		1	103	
CONDENSER-AC 12LX18HX3.12T-5RW	055813-2		1	103	
CONTROL-THERMISTOR-MIX LVL	X63019-SER	1	2	103	
COVER A.-HOPPER*358*	X51658	1	2	103	
DECAL-DEC-TAYLOR 358	056569	1		000	
DECAL-DEC-TAYLOR	021872		1	000	
DECAL-INST-CLN HPR	019029	1	1	000	
DECAL-TROUBLESHOOTING	038374	1		000	
DIAGRAM-WIRING *358*	063532-27	1		000	208-230V 60HZ 1PH
DIAGRAM-WIRING *358*	063532-33	1		000	208-230V 60HZ 3PH
DIAGRAM-WIRING *359*	065467-33		1	000	
DOOR A.-1 SPT-7 QT	X30272-SER	1	2	103	
+ GASKET-DOOR 5.177ID X 5.938OD	016672	1	2	000	
+ VALVE A.-DRAW *358*	X46028	1	2	103	
+ O-RING-1-1/16 OD X.139W	020571	2	4	000	
DRYER-FILTER-HP62-3/8 X 1/4S	048901	1	2	000	
ELEMENT-HEATER	014174-	1		000	NO LONGER USED AFTER J5050000
FASTENER-CLIP 1/4-20 U-TYPE	045865	8	18	000	
FILTER-AIR 13X16-7/8X7/16	046044	1		000	
FILTER-AIR-18.00LX13.50HX.70W	052779-3		2	000	

DESCRIPTION	PART NUMBER	QTY. 358	QTY. 359	WARR. CLASS	REMARKS
FILTER-CORCOM 2VR1	032567	1	2	000	
GUIDE A.-DRIP PAN*358*W/SHROUD	X68531	1		000	208-230V 60HZ 1PH
GUIDE A.-DRIP PAN *358*359	X45985	1	2	103	208-230V 60HZ 3PH
HARNESS A.-WIRE *358*BTR MTR	X58286	1		103	208-230V 60HZ 1PH
HARNESS-WIRE-POWER *358*	059448-27	1		103	208-230V 60HZ 1PH
HARNESS-WIRE-POWER *358*	059448-33G	1		103	208-230V 60HZ 3PH
HARNESS-WIRE *359* COMPR	065506-G		2	103	
HARNESS-WIRE *359* BTR MTR	065507		2	103	
HARNESS-WIRE *359* CTRL BX/CHN	065508		2	103	
HARNESS-WIRE *359* MAIN POWER	065509		1	103	
HARNESS-WIRE *359* BLOWER	065512		1	103	
KIT A.-WENDY'S*358*SPACER&GRIP	X51432	1		103	DRAW SWITCH ASSEMBLY
KIT A.-TUNE UP*358*	X46050	1		000	
BEARING-FRONT	013116	1		000	
GASKET-DOOR 5.177ID X 5.938OD	016672	1		000	
O-RING-.643 OD X .077W	018572	2		000	
O-RING-1-1/16 OD X.139W	020571	2		000	
SEAL-DRIVE SHAFT	032560	1		000	
TOOL- O-RING REMOVAL	048260-WHT	1		000	
KIT A.-TUNE UP	X36356		1	000	
BEARING-FRONT	013116		2	000	
GASKET-DOOR 5.177ID X 5.938O	016672		2	000	
O-RING-.643 OD X .077W	018572		4	000	
O-RING-1-1/16 OD X.139W	020571		4	000	
SEAL-DRIVE SHAFT	032560		2	000	
TOOL-O-RING REMOVAL-FREEZER	048260-WHT		1	000	
LABEL-3PH MTR PROT/1PH C-	025949	1	1	000	208-230V 60HZ 3PH
LABEL-CK MTR ROTATE-CCW-M	046867	1	1	000	208-230V 60HZ 3PH
LABEL-DOOR-MOVE PART	032749	1	1	000	
LABEL-SW-WASH/OFF/AUTO-SYMBOL	014502	1	2	000	

DESCRIPTION	PART NUMBER	QTY. 358	QTY. 359	WARR. CLASS	REMARKS
LABEL-WARN-CONDENSER-SHARP	059287	1	3	000	
LABEL-WARN-COVER	051433	5	5	000	
LIGHT-AMBER	075724	1	2	103	
LUBRICANT-TAYLOR 4 OZ.	047518	1	1	000	
MAN-OPER 358/359	056788-M	1	1	000	
MOTOR-1.5 HP	021522-27	1		212	208-230V 60HZ 1PH
MOTOR-1.5 HP	021522-33	1	2	212	208-230V 60HZ 3PH
MOTOR-FAN 80 WATT 1550 RPM CW	051744-27	1		103	
+ FAN-5 BLADE 12" PUSH 26DEG CCW	029771	1		103	
MOTOR-FAN 208-230V 50/60 HZ	053481-27		1	103	
+ CAPACITOR-RUN 7.5UF/370V	034749		1	103	
NUT-STUD *GENERAL USAGE*	021508	4	8	103	HANDSCREWS
PAN A.-DRIP *358*	X50879	1	2	103	
PANEL A.-FRONT *358*	X45987	1		103	
PANEL-REAR *358*	046021	1		103	
PANEL-SERVICE *358*	048267	1		103	
PANEL-SIDE *358*LEFT	046022	1		103	
PANEL-SIDE-RIGHT *358*AC	046023-SP1	1		103	
PANEL A.-FRONT *359*	X65223		1	103	
PANEL-REAR *359*	065271		1	103	
PANEL-SERVICE FRONT *359*	065268		1	103	
PANEL-SIDE-LEFT *359*	065250		1	103	
PANEL-SIDE-RIGHT *359*	065251		1	103	
PLATE-DEC-358	046010	1		103	
PLATE-DEC *359*	065276		1	103	
PROBE A.-MIX OUT-SQUARE HOLE	X46024	1	2	103	
PROBE-THERMISTOR-BARREL-2% TOL	038061-BLK	1	2	103	
PULLEY-10J-1.125PD-5/8BORE	028857	1	2	103	BEATER MOTOR
PULLEY-10J-11"PD-5/8BORE	025570	1	2	103	GEAR
PULLEY-IDLER 3.00PD X 1.49"	054826	1	2	103	

DESCRIPTION	PART NUMBER	QTY. 358	QTY. 359	WARR. CLASS	REMARKS
+ BOLT- IDLER PULLEY *358*	046039	1	2	103	
RELAY-3 POLE-20A-208/240 50/60	066795-33	1	2	103	
RELAY-DPDT-20A-120/240/277V	026581-27		2	103	
SANITIZER-STERA SHEEN -GREEN	055492	1	1	000	
SHAFT-BEATER	033235	1	2	103	
+ SEAL-DRIVE SHAFT	032560	1	2	000	
SHELL A.-INSULATED *358*	X45916-SER	1		512	
+ STUD-NOSE CONE	054748	4		103	
SHELL A.-INSULATED DUAL *359	X68132		1	512	
+ STUD-NOSE CONE	054748		8	103	
SHIELD-SPLASH	066697	1		103	
SHIELD-SPLASH-WIRE-19-3/4 L	033813		1	103	
STARTER-1 PHASE 6.3 TO 10 AMP	066794-27K	1		103	208-230V 60HZ 1PH
OVERLOAD-THERMAL-1P-6.3/10A	067461-1K	1		103	
STARTER-3 PHASE 4 TO 6.5 AMP	066794-33J	1	2	103	208-230V 60HZ 3PH
OVERLOAD-THERMAL-3P-4.0/6.5A	067461-3J		2	103	
SWITCH A.-DRAW *358*	X51432	1		103	
ACTUATOR-SWITCH	032247	1		103	
BEARING-SWITCH	054385	2		103	
BRACKET-SWITCH *358*	054277	1		103	
E-RING 5/16 SS	016422	1		000	
INSULATOR-SWITCH 1/64 ARMITE	029099	1		000	
ROD-SWITCH *350-1-450-1*	029135	1		103	
SPRING-COMP.480X.047X2.00 SS	025452	1		103	
SWITCH-PLUNGER-SPDT15A125-25	032260	2		103	
SWITCH A.-DRAW *359*	X65212-SER		2	103	
ACTUATOR-SWITCH	032247		2	103	
BEARING-SWITCH	054385		4	103	
BRACKET-SWITCH *358*	054277		1	103	
E-RING 5/16 SS	016422		2	000	

DESCRIPTION	PART NUMBER	QTY. 358	QTY. 359	WARR. CLASS	REMARKS
INSULATOR-SWITCH 1/64 ARMITE	029099		2	000	
ROD-SWITCH *350-1-450-1*	029135		2	103	
SPRING-COMP.480X.047X2.00 SS	025452		2	103	
SWITCH-PLUNGER-SPDT15A125-25	032260		4	103	
SWITCH-PRESSURE 405 PSI-SOLD	052663	1	2	103	DISCHARGE LINE
SWITCH-TOGGLE-DPDT*ON-OFF-ON	014464	1	2	103	POWER
GUARD-POWER SWITCH	034830-1	1	2	103	K4013676/UP
TRANS.-240V PR1/24V SEC 10 VA	030132-27	1	2	103	
TRAY-DRIP	066696	1		103	
SWITCH-PRESSURE 440 PSI-SOLDER	048230	1		103	H4102700/UP
SWITCH-PRESSURE	025749	1		103	H4102699/PRIOR
TRAY-DRIP-19-5/8 L X 4-7/8	033812		1	103	
TUBE-CAPILLARY .021ID X 9 FT	020059	1	2	103	LINE A.-LIQUID
TUBE-FEED-NON REVERS 1/4 HOLE	015176-5	1	2	103	J7030970/UP
VALVE-ACCESS-1/4MFL X 3/8ODS	053565	2	4	103	ACCESS LINE - DISCHARGE LINES
VALVE-ACCESS 1/4FL X 1/4SOLDER	044404	1	2	103	EPR VALVE
VALVE-EPR 1/4S	022665	1	2	103	
VALVE-EXP-AUTO-1/4S X1/4 FPT	046365	1	2	103	J4102700/UP
+ BOOT-EXPANSION VALVE	050900	1	2	000	
VALVE-ACCESS 1/4FL X 3/8SOLDER	043232	1		103	HEAT EXCHANGER
VALVE-ACCESS-1/4 MFLX1/4 S-90	047016	1		103	USE W/ 047519-27 COMPRESSOR
VALVE-ACCESS-1/4FLX5/16 SOLDER	053026	1		103	USE W/ 047519-27F COMPRESSOR

DESCRIPTION	PART NUMBER	QTY. 358	QTY. 359	WARR. CLASS	REMARKS
WATER COOLED					
ACCUMULATOR-COPPER 2"DIA 10"	047062	1		103	
ADAPTOR-3/8MP X 1/2 BARB-	011021	1		103	
BLOWER-100 CFM	012796-27	1		103	
CONDENSER-WC-COAX	048287	1		103	
COUPLING-ANCHOR 3/8FPTX1-	046203	1		103	
GUARD-BLOWER	022505	1		103	
HOSE-RUBBER 1/2 ID X 7/8 OD	R50200	5'		000	
PANEL-SIDE-RIGHT *358*WC	046023	1		103	
VALVE-ACCESS-1/4MFL X 3/8ODS	053565	1		103	
SWITCH-PRESSURE 350 PSI-SOLD	048231	1		103	
VALVE-WATER 3/8 REG/HEAD	046686	1		103	

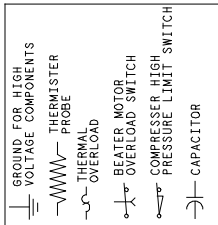

SYMBOL TABLE

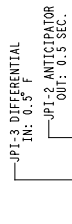

JPI JUMPER DETAIL

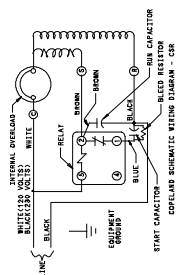
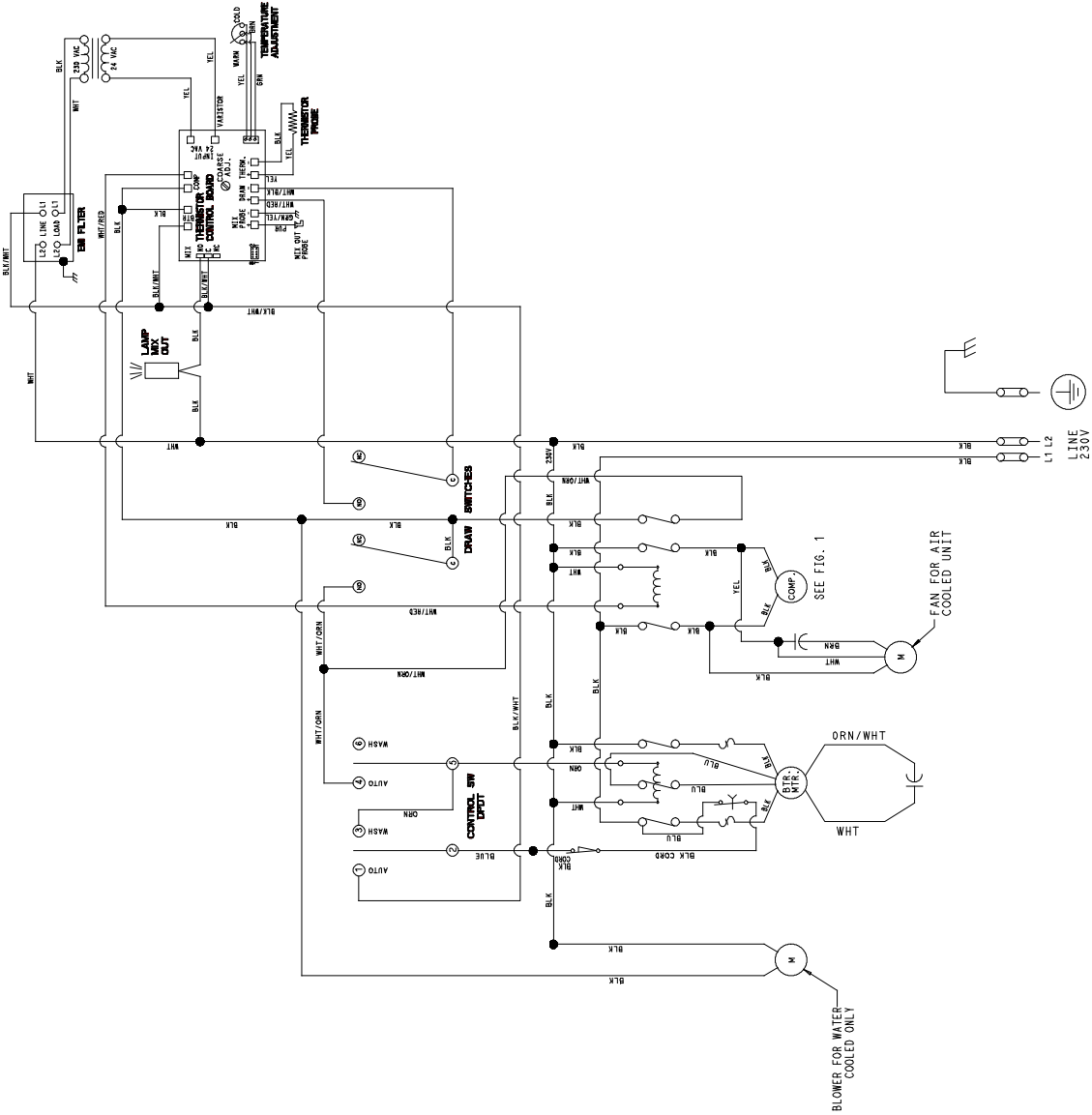

FIG. 1

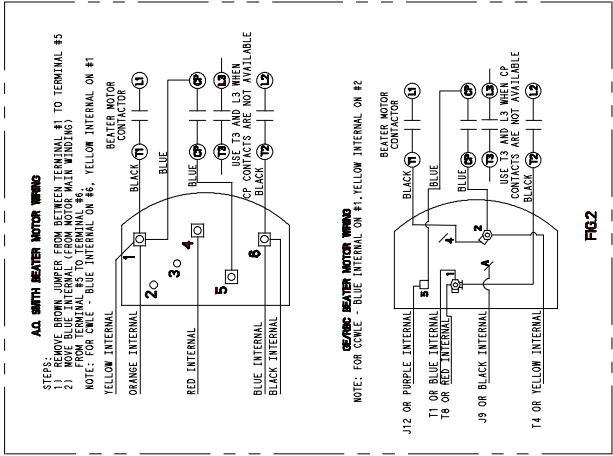
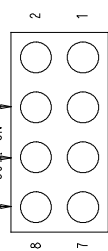

FIG. 2

GROUND FRAME SECURELY

	GROUND FOR HIGH VOLTAGE COMPONENTS
	THERMISTER
	THERMAL PROBE
	BEATER MOTOR
	OVERLOAD SWITCH
	COMPRESSOR HIGH PRESSURE LIMIT SWITCH
	CAPACITOR

SYMBOL TABLE



JPI JUMPER DETAIL

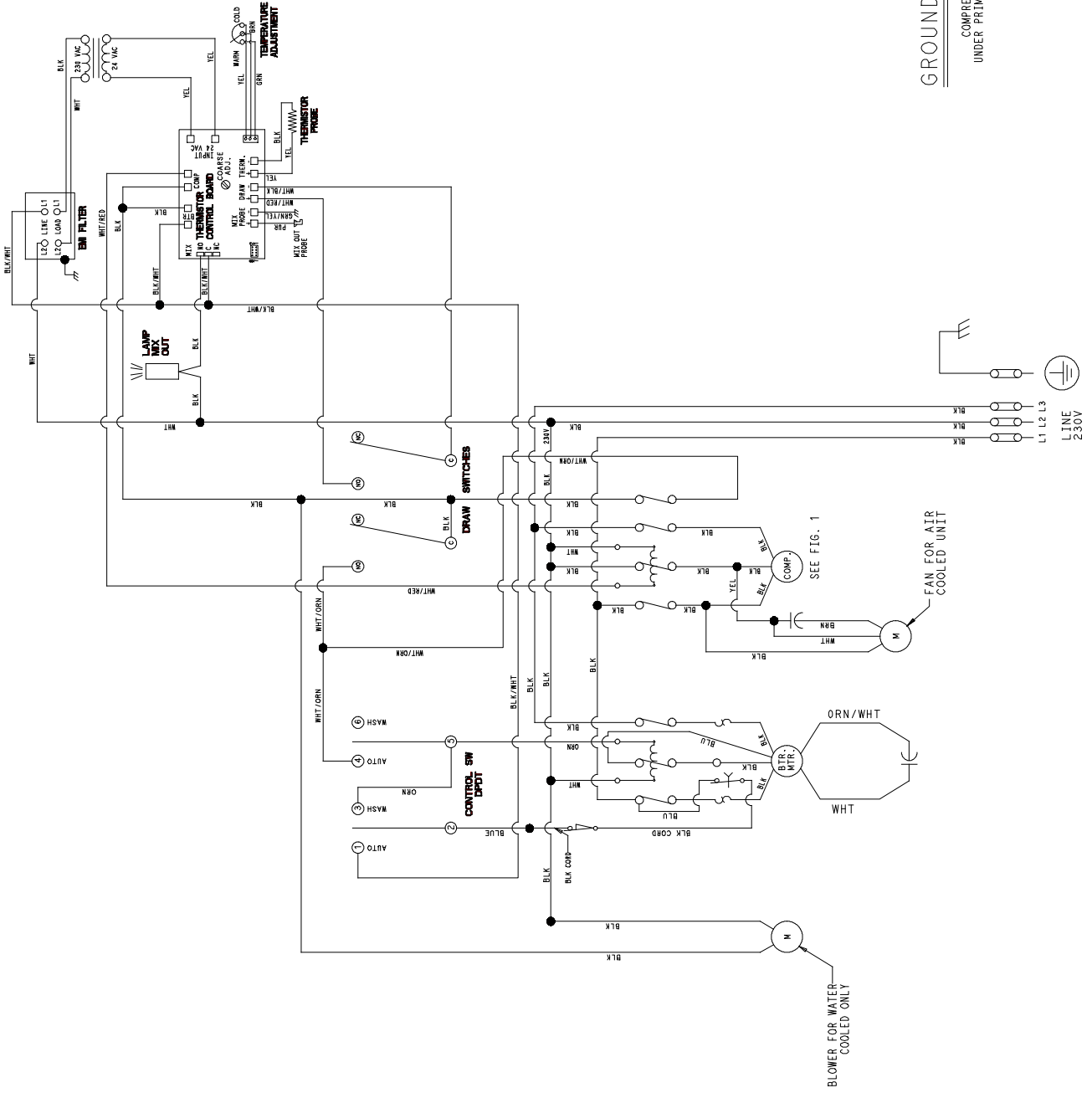

GROUND FRAME SECURELY

COMPRESSOR AND BEATER PROTECTED UNDER PRIMARY PHASING CONDITIONS

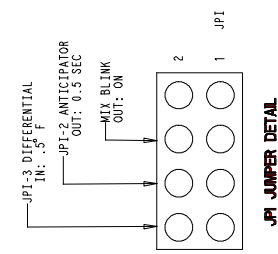
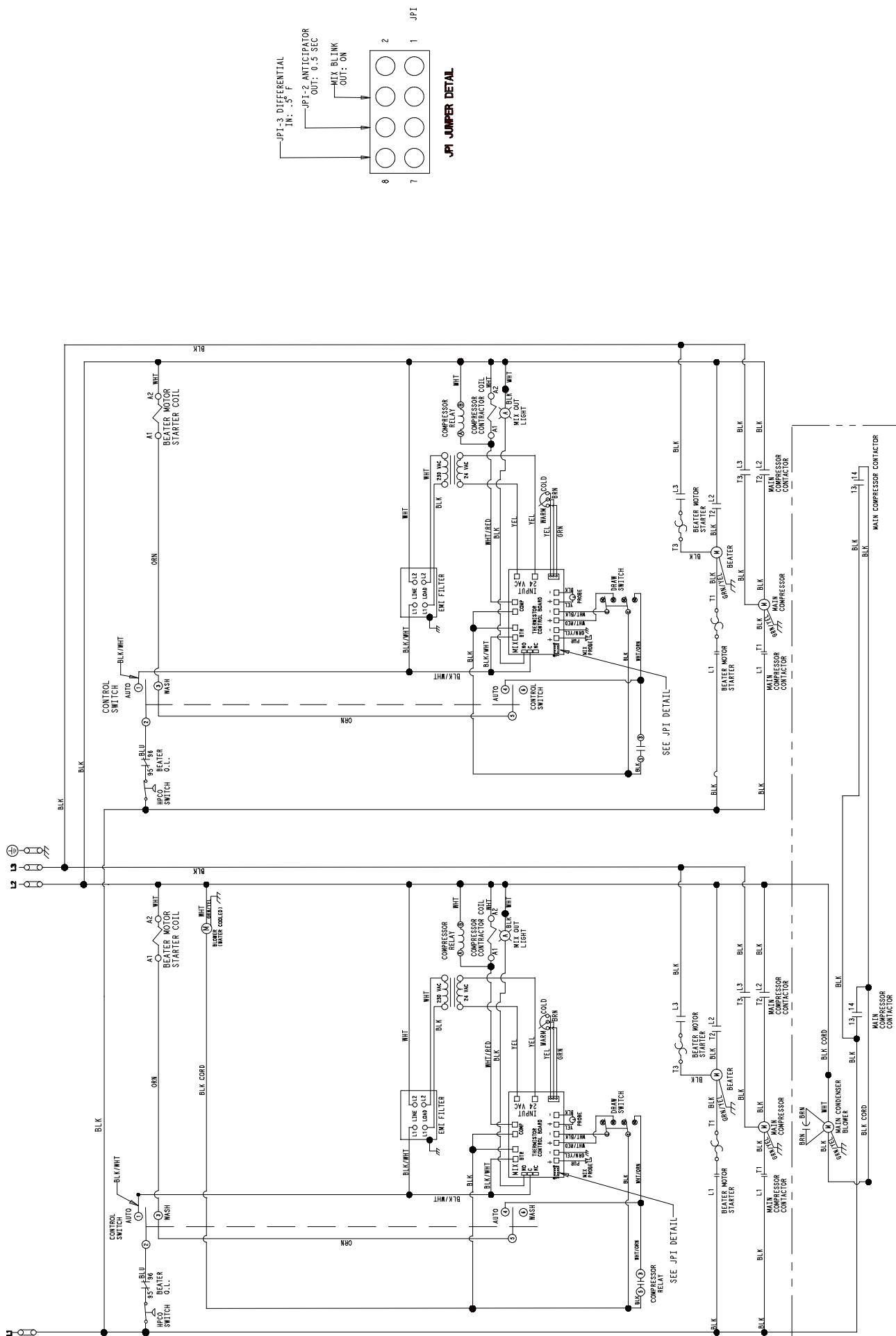

Model 359
065467-33
 Rev. 3/11